

STENHØJ ClassicPress



Standard equipment

CP 16 – CP25 – CP 40 – CP 60 – CP 100

- Single-acting cylinder with internal spring return
- Adjustment of press bed with winch
- 2 pcs. Straightening blocks
- Replaceable nose cap

Function and operation

Hand pump unit

- The hand pump is a 2-stage model, which is equipped with double pistons
- Manual changeover from low to high pressure on the selector valve

Foot pump unit

- The foot pump is a 2-stage model, which is equipped with double pistons
- Changeover to return with foot-operated valve

Option

- Manual adjustment of press table (CP16-CP25)

Built in accordance with the latest EC regulations and CE labelled.



STENHØJ

ClassicPress excl. pump unit

MODEL			CP16	CP25	CP40	CP60	CP100
Pressing force, max.		kN	160	250	400	600	1000
Stroke		mm	180	180	180	200	200
Daylight, min.	A	mm	150	160	185	205	245
Daylight, max.	B	mm	900	785	810	705	745
Width between uprights l-r	C	mm	640	740	850	1010	1080
Floor space	D	mm	780	910	1030	1270	1440
Clearance between verticals	F	mm	130	160	245	290	360
Depth, foot	H	mm	570	590	610	760	800
Overall height	K	mm	1800	1825	1880	2000	2280
Bed height, max.	L	mm	1100	1060	1100	1060	1190
Width between upright holes	M	mm	6x125	6x125	5x125	4x125	4x125
Diameter, nose cap	S	Ømm	50	60	65	85	100
Weight		kg	180	250	450	750	1200
MODEL			16H	25H	40H	60H	100H
Width	O ₁	mm	150	150	180	180	180
Piston travel/pump stroke LP/HP		mm	5,7/0,8	3,5/0,5	7/1	4,4/0,6	3/0,4
Oil reservoir capacity		liter	2	2	14	14	14
MODEL			16F	25F			
Width	O ₂	mm	105	105			
Piston travel/pump stroke LP/HP		mm	5,7/0,8	3,5/0,5			
Oil reservoir capacity		liter	2	2			

H: Operation

S: Winch

Example of order: ClassicPress model CP 40 H-S

Subject to changes without notice.

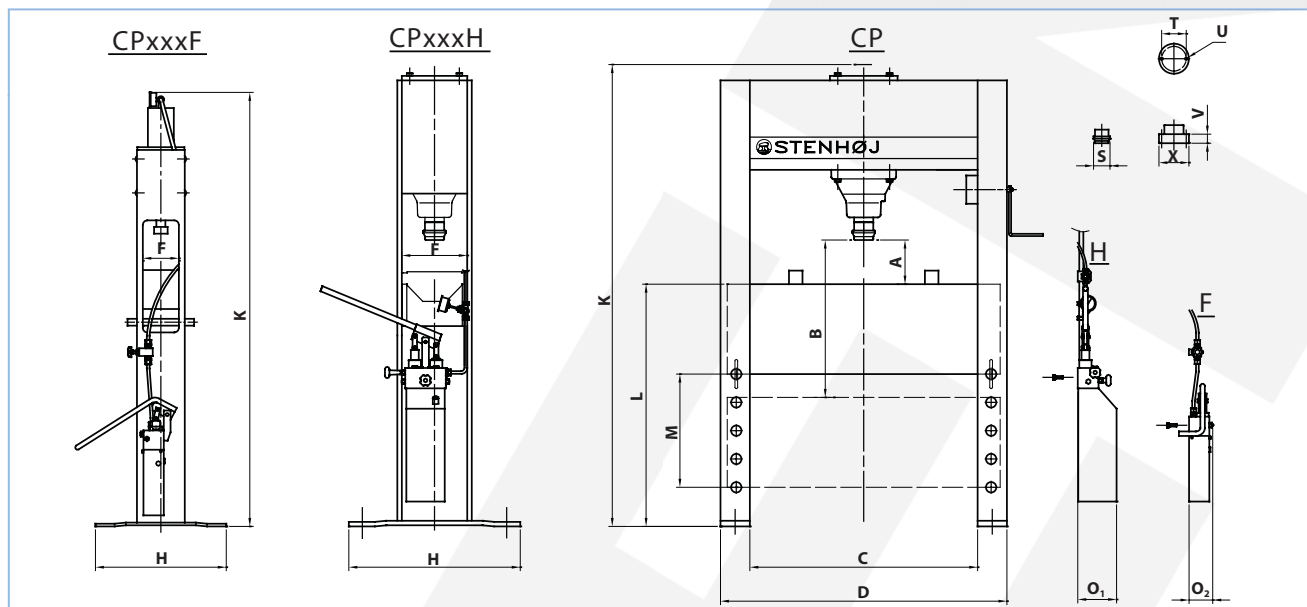

STENHØJ

STENHØJ HYDRAULIK A/S

DK-7150 Barrit

Phone: +45 7682 1322 • Fax: +45 7682 1300

hydraulik@stenhoj.dk • www.stenhoj.dk